

PREDICTION SYSTEMS WITH DATA ASSIMILATION FOR COUPLED OCEAN SCIENCE AND OCEAN ACOUSTICS

Keynote address

ALLAN R. ROBINSON
PIERRE F.J. LERMUSIAUX

*Division of Applied Sciences, Harvard University, 29 Oxford Street
Cambridge, MA 02138, USA*

Ocean science and ocean acoustics today are engaged in coupled interdisciplinary research on both fundamental dynamics and applications. In this context interdisciplinary data assimilation, which melds observations and fundamental dynamical models for field and parameter estimation is emerging as a novel and powerful methodology, but computational demands present challenging constraints which need to be overcome. These ideas are developed within the concept of an interdisciplinary system for assessing sonar system performance. An end-to-end system, which couples meteorology-physical oceanography-geoacoustics-ocean acoustics-bottom-noise-target-sonar data and models, is used to estimate uncertainties and their transfers and feedbacks. The approach to interdisciplinary data assimilation for this system importantly involves a full, interdisciplinary state vector and error covariance matrix. An idealized end-to-end system example is presented based upon the Shelfbreak PRIMER experiment in the Middle Atlantic Bight. Uncertainties in the physics are transferred to the acoustics and to a passive sonar using fully coupled physical and acoustical data assimilation.

1 Introduction

Interdisciplinary ocean science today now involves research on coupled physical, biological, chemical, sedimentological, acoustical and optical processes. Research advances in interdisciplinary ocean science have led to the emergence of new dynamical concepts in which non-linear interdisciplinary processes are now known to occur on multiple interactive scales in space and time with bi-directional feedbacks. Such processes importantly can be dominated by strong sporadic events that are intermittent in space and time. Understanding specific non-linear dynamics of known events and identifying important additional as yet unknown multi-scale interactive processes provides a framework for realistic representation and prediction of the interdisciplinary coastal ocean [12].

Ocean prediction for science and operational applications has now been initiated on global, basin and regional scales [13]. A system approach that synthesizes theory, data and numerical computations is essential for efficient and rapid progress in interdisciplinary ocean science and prediction [17]. The concept of Ocean Observing and Prediction Systems for field and parameter estimations has recently been crystallized with three major components: i) an observational network: a suite of platforms and sensors for specific tasks; ii) a suite of interdisciplinary dynamical models; and, iii) data management, analysis and, importantly, *data assimilation* schemes. Systems are modular, based on distributed information providing shareable, scalable, flexible and efficient workflow.

Data assimilation is a modern methodology of relating natural data and dynamical models [16]. The general dynamics of a model is combined or melded with a set of

observations. All dynamical models are to some extent approximate, and all data sets are finite and to some extent limited by error bounds. The purpose of data assimilation is to provide estimates of nature that are better estimates than can be obtained by using only the observational data or the dynamical model. There are a number of specific approaches to data assimilation that are suitable for estimation of the state of nature, including natural parameters, and for evaluation of the dynamical approximations. Generally data assimilation demands large computational resources and efficient computational algorithms are essential. Interdisciplinary data assimilation can contribute powerfully to understanding and modeling physical-acoustical-biological processes and is essential for ocean field prediction and parameter estimation [15]. Model-model, data-data and data-model compatibilities are essential and dedicated interdisciplinary research is needed.

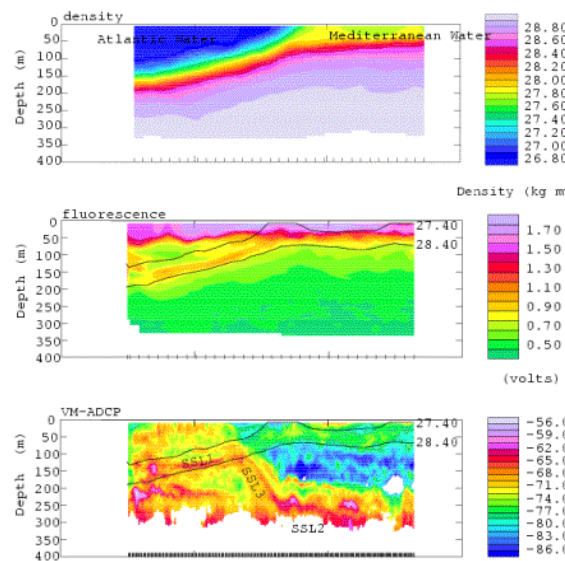

Figure 1. Density, fluorescence and acoustic backscatter across the Alneira-Oran Front in the Mediterranean Sea (from [4]).

To illustrate these ideas, Figure 1 presents a set of simultaneous physical, optical and acoustical measurements obtained in the region of the Alneira-Oran Front in the Mediterranean Sea. The purpose of these measurements was to study coupled biological-physical frontal dynamical processes. Hydrographic measurements directly provide the sea-water density distribution, fluorescence is a proxy for phytoplankton density and acoustic backscatter is a proxy for zooplankton density. The density front separates Atlantic water from Mediterranean waters. Drawn down phytoplankton are concentrated at the front and further details are found in [4, 5]. The methodological approach that can best exploit the dynamical information in such measurements is data assimilation. A single multi-variate state vector for the physical, biological, optical and acoustical state variables should be defined. The error covariance matrix that determines the relative weights of data and dynamics in the melded estimates should include the covariances among all the physical, biological, optical and acoustical variables. Importantly, in addition to backscatter data, acoustical propagation data can enhance interdisciplinary dynamical studies and ocean prediction efforts [2].

The theme of this presentation is that coupled ocean scientific and ocean acoustical data assimilation presents novel and powerful opportunities and challenges for theoretical and especially computational acoustics. In the next section we will introduce the particular interdisciplinary system (physical/geological/acoustical/signal-processing/sonar- system) to be studied. Section 3 further develops data assimilation methods, Section 4 applies the system and the method to the Shelfbreak PRIMER data set and Section 5 concludes.

2 End-to-End System Concept

Advanced sonar performance prediction requires end-to-end scientific systems: ocean physics, bottom geophysics, geoacoustics, underwater acoustics, sonar systems and signal processing. The littoral environment can be highly variable on multiple scales in space and time, and sonar performance is affected by these inherent variabilities. Uncertainties arise in estimates of oceanic and acoustic fields from imperfect measurements (data errors), imperfect models (model errors), and environmental variabilities not explicitly known. A conceptual basis has been developed to achieve the following: i) generic methods to efficiently characterize, parameterize, and prioritize system variabilities and uncertainties arising from regional scales and processes; ii) error, variability and uncertainty models for the end-to-end system and its components to address forward and backward transfer of uncertainties; and, iii) transfers of uncertainties from the acoustic environment to the sonar and its signal processing in order to effectively characterize and understand sonar performance and predictions. In order to accomplish these objectives, an end-to-end system approach is necessary [13].

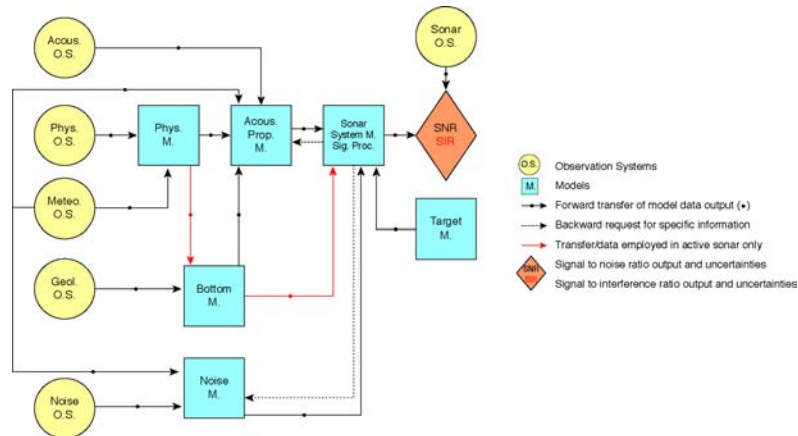

Figure 2. Schematic diagram of the end-to-end system from a model point of view (from [13]).

Figure 2 schematizes the end-to-end system from the model point of view, where models are used to represent each of the coupled dynamics (boxes) and also the linkages to observation systems (circles). An effort was made to make the diagram exact but as simple as possible. The diagram illustrates the forward transfer of information, including uncertainties, in terms of observed, processed and model data (dots on arrows) and products and applications (diamond). The system concept encompasses the interactions and transfers of information with feedback from: i) observing systems, the information

being meteorological-physical oceanographic-acoustical-bottom-noise-target-sonar data, and, ii) coupled dynamical models, the information being physical-acoustical-bottom-noise-sonar state variables and parameters.

Specific applications require the consideration of a variety of specific end-to-end systems. Note the backward pointing dotted arrows coming from the sonar model which indicate that the specifics of the sonar system determines e.g. the acoustic propagation calculations required. To specify an application requires the choice of: i) observational circles and model boxes to be included; ii) data types and sampling schemes; and, iii) appropriate form of the dynamical models to be used. Some of the wide range of approximate dynamics useful for various oceanic purposes are shown in Table 1.

Table 1. Coupled (Dynamical) Models and Outputs.

Models	Types	Outputs
Physical	<ul style="list-style-type: none"> • Non-hydrostatic models (PDE, x,y,z,t) • Primitive-Eqn. models (PDE, x,y,z,t) • Quasi-geostrophic, shallow-water models • Objective maps, balance eqn. (thermal-wind) • Feature models 	<ul style="list-style-type: none"> • T, S, velocity fields and parameters, C field • Dynamical balances
Acoustic Propagation	<ul style="list-style-type: none"> • Parabolic-Eqn. models ($x,y,z,t/f$) • (Coupled)-Normal-Mode parabolic-eqn. (x,z,f) • Wave number eqn. models (x,z,f: OASIS) • Ray-tracing models (CASS) 	<ul style="list-style-type: none"> • Full-field TL (pressure p, phase j) • Modal decomposition of p field • Processed series: arrival strut., travel times, etc. • CW / Broadband TL
Reverberation (active)	<ul style="list-style-type: none"> • Surface, volume and bottom scattering models 	<ul style="list-style-type: none"> • Scattering strengths
Bottom	<ul style="list-style-type: none"> • Hamilton model, Sediment flux models (G&G), etc • Statistical/stochastic models fit-to-data 	<ul style="list-style-type: none"> • Wave-speed, density and attenuation coefficients
Noise	<ul style="list-style-type: none"> • Wenz diagram • Empirical models/rule of thumbs 	<ul style="list-style-type: none"> • f-dependent ambient noise ($f;x,y,z,t$): due to sea-surface, shipping, biologics
Sonar system and signal processing	<ul style="list-style-type: none"> • Sonar equations ($f;t$) • Detection, localization, classification and tracking models and their inversions 	<ul style="list-style-type: none"> • SNR, SIR, SE, FOM • Beamforming, spectral analyses outputs (time/frequency domains)
Target	<ul style="list-style-type: none"> • Measured/Empirical 	<ul style="list-style-type: none"> • SL, TS for active

3 Interdisciplinary Data Assimilation

Data assimilation provides a powerful methodology for state and parameter estimation via the melding of data and dynamics. It makes feasible such estimates on a substantial and sustainable basis. The general process is schematized in Figure 3. Sensor data are linked to state variables and parameters and transformed as appropriate for the dynamical model via measurement models. Dynamics interpolates and extrapolates the data. Dynamical linkages among all the state variables and parameters allows all of them to be estimated from observations of some of them (i.e., those more accessible to existing techniques and prevailing conditions). Error estimation and error models play a crucial role. Using data assimilation schemes, data and dynamics are melded, often with weights inversely related to their relative errors. The melding is based on an assimilation criterion involving a cost or penalty function. The final estimates should agree with the observations and measurements within data error bounds and should satisfy the dynamical model within model error bounds. There are many important feedbacks in the generally highly nonlinear ocean observing and prediction system schematized in Figure 3, which illustrates the system concept and three feedbacks. Prediction provides the opportunity of efficient sampling schemes adapted to real-time structures, events, and errors. Data collected for assimilation also used for ongoing validation can identify model deficiencies and lead to model improvement, including the adaptation of the approximate models in real-time [15].

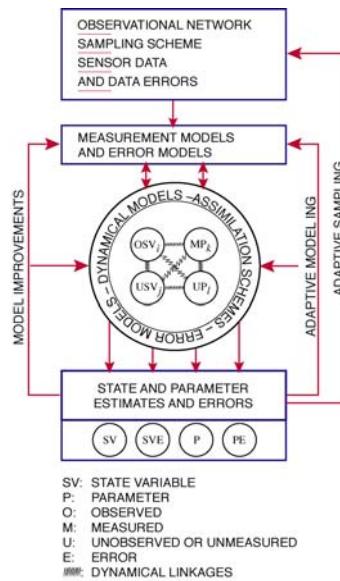

Figure 3. Illustration of a generic Ocean Observing and Prediction System with data assimilation.

Mathematically, the generic data assimilation problem is represented in terms of:

Dynamical models

$$d\phi_i + \underline{v} \cdot \nabla \phi_i dt - \nabla \cdot (K_i \nabla \phi_i) dt = B_i(\phi_1, \dots, \phi_i, \dots, \phi_n) dt + d\eta_i \quad (i = 1 - n)$$

Parameter (P) equations

$$d\Pi_l = C_l(\phi_1, \dots, \phi_i, \dots, \phi_n)dt + d\zeta_l \quad (l = 1, \dots, p)$$

Measurement models

$$y_j = H_j(\phi_1, \dots, \phi_i, \dots, \phi_n) + \varepsilon_j \quad (j = 1, \dots, m)$$

Assimilation criterion

$$\underset{\varphi_i, \Pi_l}{Min} J(d\eta_i, d\zeta_l, \varepsilon_j, q_\eta, q_\zeta, q_\varepsilon)$$

In the dynamical models, ϕ_i is a generic state variable (e.g. $i = u, v, T, \dots, Zoo, \dots$), t is time, \underline{v} the velocity vector and K_i a diffusivity. The first term on the left is local time change at a point, the second advection and the third diffusion. On the right, the term B_i represents sources and sinks of ϕ_i ; the stochastic forcings $d\eta_i$ the model uncertainties. Model parameters (diffusivities, bottom attenuations, etc.), $\Pi_l = \{K_l, R_l, \dots\}$, are also represented by an equation with stochastic forcings $d\zeta_l$, where C_l are functionals that describe the possible deterministic evolution of parameters with time and space. The state variables ϕ_i are related to the data y_j , e.g. $y_j = \{XBT_j, SSH_j, Fluo, \dots\}$, via measurement models, also with stochastic forcings ε_j . The assimilation or melding criterion involves the minimization of a functional J of the stochastic or error forcings $d\eta_i$, $d\zeta_l$ and ε_j , and of their *a priori* statistical properties or weights denoted by q_η , q_ζ and q_ε , subject to the constraints the other equations. The three sets of equations and assimilation criterion define the assimilation problem (Fig. 3). For state estimation, we refer to the estimates just before (forecast) and just after (nowcast) data assimilation as *a priori* and *a posteriori* respectively. For parameter estimation, *a priori* and *a posteriori* refer to parameter values at the beginning and at the conclusion of the optimization. Data residuals or data-model misfits refer to the differences between the data and model-estimated values of the data.

For the coupled physical-acoustical assimilation problem of interest here, the coupled discrete vector X , associated with the continuous vector ϕ_i is the combined $X = [X_A \ X_O]$, where the physics is represented by $X_O = [T, S, U, V, W]$ and the acoustics is represented by $X_A = [\text{Pressure}(p), \text{Phase}(\varphi)]$. The coupled error covariance for the state defined by

$$P = \varepsilon \{(\hat{X} - X^t)(\hat{X} - X^t)^T\} \quad \text{corresponds to } P = \begin{bmatrix} P_{AA} & P_{AO} \\ P_{OA} & P_{OO} \end{bmatrix}.$$

The error covariance P is of paramount importance for the coupled assimilation, here the minimum error variance update defined by,

$$X_+ = X_- + PH^T [HPH^T + R]^{-1} (y - HX_-),$$

where X_- is the *a priori* estimate and X_+ the *a posteriori* estimate. The matrix H corresponds to the coupled measurement models and the matrix R is the coupled data error covariance.

Specific classes of data assimilation schemes are listed in Table 2. Specific schemes are overviewed in [16].

Table 2. Classes of Data Assimilation Schemes

Class	Examples	Important Properties
Estimation Theory (Filtering and Smoothing)	<ol style="list-style-type: none"> 1. Direct Insertion, Blending, Nudging 2. Optimal interpolation 3. Kalman filter/smoothen 4. Bayesian estimation (Fokker-Plank equations) 5. Ensemble/Monte-Carlo methods 6. Error-subspace/Reduced-order methods: Square-root filters, e.g. SEEK 7. Error Subspace Statistical Estimation (ESSE): 5 and 6 	<ol style="list-style-type: none"> 1. Linear 2. Linear, Least Squares (LS) 3. Linear, LS 4. Non-linear, Non-LS 5. Non-linear, LS/Non-LS 6. (Non)-Linear, LS 7. Non-linear, LS/Non-LS
Control Theory - Calculus of Variations (Smoothing)	<ol style="list-style-type: none"> 1. "Adjoint methods" (with descent) 2. Generalized inverse (e.g. representer method with descent) 	<ol style="list-style-type: none"> 1. Linear, LS 2. Linear, LS
Optimization Theory (Direct local/global smoothing)	<ol style="list-style-type: none"> 1. Descent methods (Conjugate gradient, Quasi-Newton, etc) 2. Simulated annealing, Genetic algorithms 	<ol style="list-style-type: none"> 1. Linear, LS/Non-LS 2. Non-linear, LS/Non-LS
Hybrid Schemes	Combinations of the above	

The ocean observing and prediction system utilized at Harvard is the Harvard Ocean Prediction System (HOPS), which is schematized in Figure 4a. The data assimilation scheme associated with HOPS, Error Subspace Statistical Estimation (ESSE) is pictured in Figure 4b. HOPS is an integrated system of data analysis and assimilation schemes, and a suite of coupled interdisciplinary (physical, acoustical, optical, biogeochemical-ecosystem) dynamical models [14]. This system was developed for producing interdisciplinary oceanic field estimates that include effective and efficient data assimilation, dynamically consistent model initialization, multi-scale nesting, and model-driven adaptive sampling with feedbacks. HOPS employs a primitive equation (PE) physical dynamical circulation model. Boundary layers (top and bottom) and isopycnal and diapycnal turbulence are modeled through process parameterization and scale-dependent filters. Multiple sigma vertical coordinates are calibrated for accurate modeling of steep topography. Multiple two-way nests are an existing option for the horizontal grids.

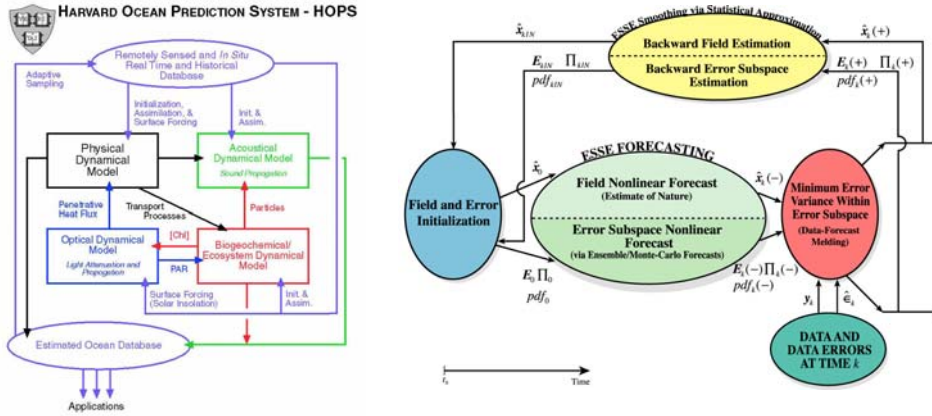

Figure 4. Schematic of (a) the Harvard Ocean Prediction System (HOPS) and (b) the Error Subspace Statistical Estimation (ESSE) procedure.

ESSE is a four-dimensional multivariate estimation scheme for physical-biogeochemical-acoustical fields and parameters that aims to capture and forecast the dominant uncertainties, i.e. the error subspace, and assimilate all relevant data to control and reduce errors [6,7,10]. Instead of characterizing and capturing all uncertainties, ESSE focuses on the uncertainties that matter. The sub-optimal truncation of the error space is itself optimal. For example, if a variance criterion is used to combine data and dynamics, the error subspace is then defined by the ordered eigen-decomposition of the error covariance. The error subspace is initialized by decomposition on multiple scales and evolved in time by an ensemble of model iterations. Initial conditions are first perturbed using random combinations of the initial error principal components. For each perturbed initial conditions, the nonlinear dynamical model (HOPS), forced stochastically to represent various model errors, is integrated until the next data time. These Monte-Carlo integrations are carried out in parallel until the size of the ensemble is large enough to describe most of the error variance forecast. This is assessed by a convergence criterion. Once the error forecast has converged, the available data are assimilated, presently based on a singular value decomposition of the minimum error variance update. After data assimilation, the posterior data residuals are computed and utilized to correct the posterior error estimates, i.e. adaptive learning of the dominant errors is carried out. Using error estimates, adaptive sampling plans are determined using schemes that are consistent with the data assimilation scheme itself. Ultimately, the ESSE smoothing can be used to correct the past estimates, including initial conditions and boundary forcings, based on the future data-model misfits and their error estimates. ESSE has been developed for and applied to both fundamental research and real-time operations. It has been used in several regions of the world's ocean for varied purposes, including error forecasting, adaptive sampling, dynamical studies, model improvements, 3D objective analyses and predictability studies. Current ESSE developments focus on a fully distributed and scalable architecture, interdisciplinary parameter estimation, adaptive sampling and adaptive modeling.

In the HOPS/ESSE methodology, the real-time initialization of the dominant error covariance decomposition is evaluated under the assumption that dominant uncertainties

are missing or that there is uncertain variability in the initial state, e.g., smaller mesoscale variability. Important issues include the fact that some state variables are not observed and that the uncertain variability is multi-scale. The evaluation approach is multi-variate, multi-scale and three-dimensional, the “observed portions” are directly specified and eigen-decomposed from differences between the initial state and data, and/or from a statistical model fit to these differences, and for the “non-observed portions” the “observed” portions are kept fixed and the “non-observed portions” are computed from an ensemble of numerical (stochastic) dynamical simulations.

4 Shelfbreak PRIMER Example

In this section we present an example to illustrate three major points: i) end-to-end uncertainty transfer through an idealized system; ii) coupled physical and acoustical data assimilation; and, iii) the careful simulation of the physical environment necessary for realistic acoustic propagation studies.

The Middle Atlantic Bight (MAB) shelfbreak marks a dramatic change, not only in water depth, but also in the dynamics of the waters that lie on either side. The shelf is about 100 km wide, extending from Cape Hatteras to Canada. The shelfbreak, which refers to the first rapid change in depth that occurs between the coastal and deep ocean, is near the 100m isobath. The main oceanographic feature in the MAB is a mesoscale front of temperature, salinity and hence sound speed, separating the shelf and slope water masses (Figure 5a). The shelf-water to the north is cold and fresh while the slope-water to the south is warm and salty. Located near the shelfbreak, this front is usually tilted in the opposite direction of the bottom slope (Figure 5b).

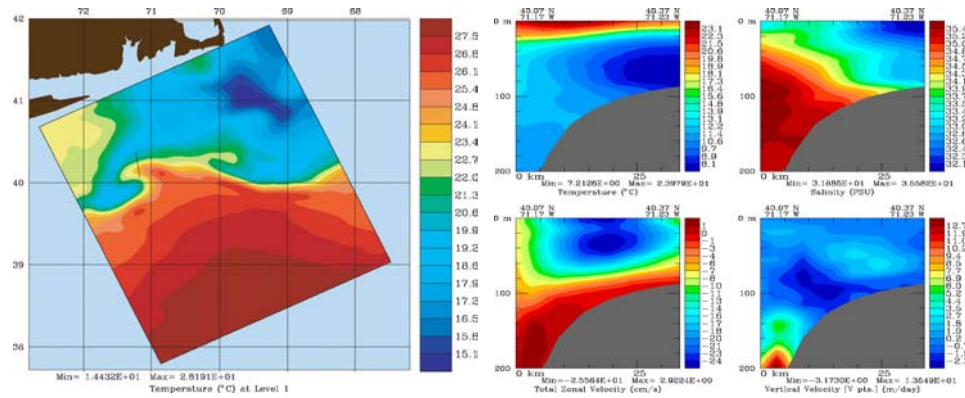

Figure 5. (a) Map of the Middle Atlantic Bight shelfbreak front, (b) Vertical sections of temperature, salinity, zonal velocity and vertical velocity across the front.

During July and August of 1996, data were collected in the MAB south of New England, as part of the ONR Shelfbreak PRIMER Experiment [11]. The main objective was to study the influence of oceanographic variability on the propagation of sound from the slope to the shelf. Intensive *in situ* measurements were carried out in a 45 km by 30 km domain between the 85 m and 500 m isobaths. The measurements consisted of temperature, salinity, velocity, chlorophyll, bioluminescence and acoustic transmissions. The physics considered here are the mesoscale dynamics of the Middle Atlantic Bight shelfbreak front, including remote influences from the shelf, slope and deep ocean. The acoustics is the transmission of low-frequency sound from the continental slope, through

the shelfbreak front, onto the shelf. These dynamics, and also the model parameters, data assimilated in the physical model, and acoustical-physical uncertainties are described in [8]. The coupled assimilation via ESSE is illustrated for the 3D physical fields and 2D transmission loss along an actual Shelfbreak-PRIMER acoustic path (Figure 6).

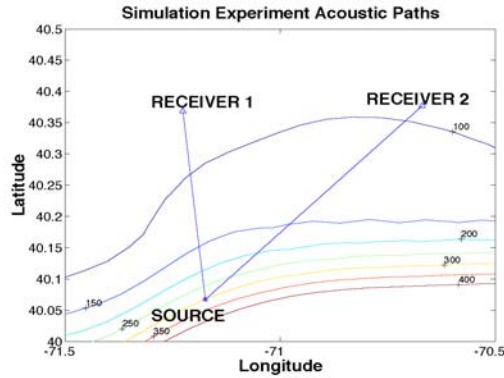

Figure 6. Acoustic paths considered overlaid on bathymetry.

The present example of the end-to-end system using PRIMER data involves the physical, acoustical and passive system components of Figure 2. The method adopted to characterize sonar performance involved the concept of Predictive Probability of Detection (PPD). Figure 7 illustrates conceptually the PPD, details of which are given in [1]. The system-based environmental PDF was derived by a comparison of model predictions with system data. A histogram of the differences between the data and the acoustic model was fit with an appropriate distribution to yield the PDF. This PDF represents the uncertainty in the computational modeling process, typically small, and the inherent variability of the environment not contained in the model inputs, which typically is larger. The PPD is a prediction of the system performance versus range. Rather than use a single range value (e.g. “range-of-the-day” or “range-of-the-moment”), the PPD provides the system operator with a probabilistic representation of the system performance. The operator can thus use this information to operate the system more effectively, and can make more informed decisions on search, risk, and expenditure of assets.

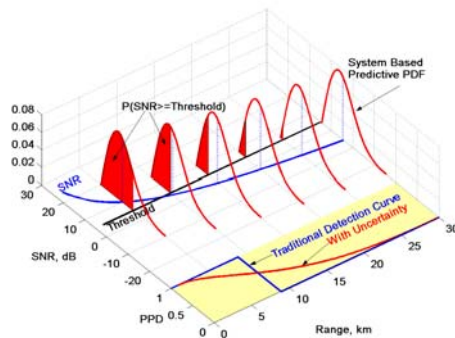

Figure 7. Example Predictive Probability of Detection (PPD)

In this example, the problem is to start with physical environmental data, transfer it through the idealized end-to-end system and compute a depth and range dependent PPD from first principals. A novel approach is used in which coupled physical-acoustical data assimilation method is used in Transmission Loss (TL) estimation. The methodology involves a coupled physical-acoustical identical-twin experiment [9] and is ESSE based.

Methodology: Uncertainty prediction, transfer, processing and reduction

ESSE is first utilized to predict uncertainties in the ocean physics, transfer them to the acoustics and compute acoustics uncertainties [10]. The approach is based on dominant error principal components and on ensembles of Monte-Carlo simulations. Specifically, the dominant physical uncertainties are initialized using a multi-scale, principal component decomposition of the initial error covariance whose parameters are a function of oceanic data and dynamical models. An ensemble of initial physical conditions for the ocean physics primitive-equation model of HOPS is then computed, in accord with this initial statistics or error subspace. For each initial realization, the ocean physics model is integrated forward in time, which produces an ensemble of physical field forecasts, providing environmental uncertainties for the volume around the acoustic region of interest. The different realizations of the sound speed field forecast, i.e. the sound speed ensemble, are then interpolated onto the vertical planes of acoustic interests and fed into the NPS coupled-mode sound propagation model. For a specific vertical plane, running the acoustics model for each sound-speed realization produces an ensemble of predicted acoustic wavefields. The resulting coupled physical-acoustical error subspace captures the dominant uncertainties in each physical and acoustical field, but also captures their (cross)-covariances and other coupled statistics.

Presently, the main acoustic variable of interest is the transmission loss (TL) because the ultimate objective is to provide uncertainty estimates for sonar systems. To obtain TL uncertainties for a broadband sonar, the above continuous-wave uncertainties for a single-frequency forecast TL are processed. A variable-width running-range average is applied to the ESSE ensemble of single-frequency TL realizations. This produces an estimate of the uncertainties in the broadband TL term of a passive sonar equation.

Once physical and/or acoustical data are available, they are combined with the model estimates via ESSE data assimilation so as to reduce errors and improve predictions. Presently, the physical and acoustical data are assimilated such that the total error variance in the error subspace is minimized. After assimilation, the a posteriori acoustical variables and corresponding (reduced) uncertainties are available. By variable-width running-range average, the a posteriori broadband TL and its uncertainties are computed. Ultimately, the coupled assimilation reduces uncertainties in the sonar predictions. This coupled uncertainty estimation and data assimilation approach is now illustrated.

Twin-experiments

The approach is exemplified in identical-twin experiments using PRIMER data [11] In such an experiment, the data are synthetic, i.e. they are output from a simulation that defines the ``truth'', and the model used to create data is identical to the one used for prediction. In the present case, the simulation defining the truth assimilates some real data to be closer to reality. Goals of such twin-experiments are to study the assimilation in an ideal situation and to find out if the *a posteriori* fields become close to the known "true" fields. Importantly, all computations are made at resolutions and on domains appropriate for each field. The acoustic 2D-space resolution is here much finer than the 3D-space

resolution of the ocean physics. In addition to the possible different scales within each discipline, there are multiple scales because of the interdisciplinary nature of the problem.

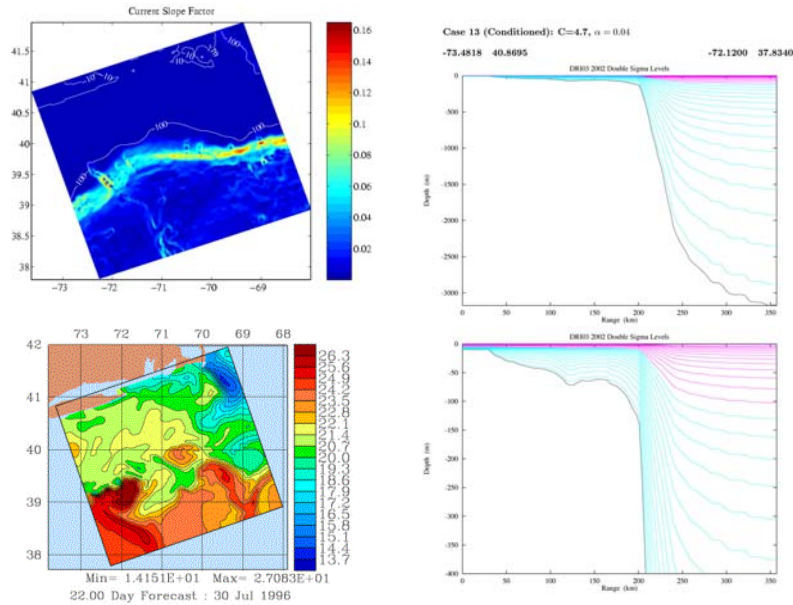
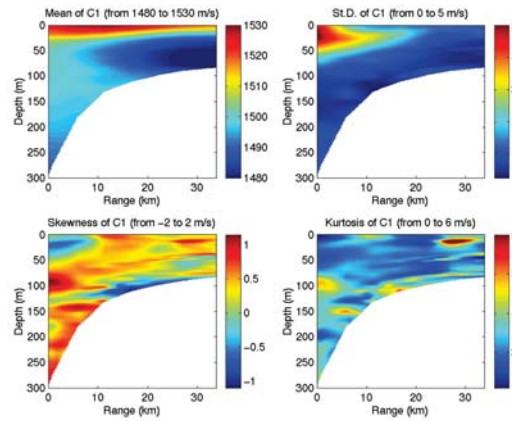

Figure 8. (a) Bottom slope used in the model, (b) optimized model levels, (c) surface temperature for PRIMER domain.

To achieve numerical predictions of the ocean physics at accuracies suited for useful acoustical computations, substantial efforts were necessary. This included compiling all data sets collected over the large-scale New England shelfbreak region relevant to the (sub)-mesoscale physics. Bathymetric data sets were collected and combined in accord with their uncertainties and biases. Numerical research (i.e. minimize numerical errors due to steep topographies/pressure gradient, non-convergence issues, pycnocline resolution, etc) was carried-out to allow the ocean physics model (HOPS) to run on accurate topographies, with almost no smoothing of the bathymetry. This was necessary for the acoustics and is illustrated on Figure 8 by the bottom slope (Fig. 8a) and optimised model levels along a cross-slope section (Fig 8b). The physical representations of boundary influences (e.g. Hurricane Bertha) and their numerics (e.g. OBC) were also improved. The latest numerical ocean simulation is illustrated in Fig. 1c. Of interest are: the impacts of a large meander of shelf water intruding slope waters at latitudes further south than usual, the corresponding upstream presence of a large slope eddy (confirmed by SST) that is pinching off from the shelfbreak front, and the strong effect of Hurricane Bertha in setting up the basis of the overall regional internal circulation.

In the present coupled assimilation via ESSE example, the synthetic representation of the “true” ocean is a 4D (x, y, z, t) ocean physics model simulation that assimilates real physical data. After 5 days in this simulation, a snapshot of the “true” ocean is taken and the corresponding “true” sound-speed field input to the 2D (r, z) acoustical coupled-normal-mode model. Running the acoustical model then leads to the “true” transmission loss (TL) field on day 5. Different synthetic physical and acoustical data were then coarsely sampled from this “true” physical-acoustical ocean. These different data sets were then successfully assimilated using ESSE. As a technical aside, the order of the

assimilation (ocean physics before acoustics, or vice-versa) does not matter and sequential processing of observations is utilized.



Mean of C1 and statistics of error estimate for C1

Figure 9. Ensemble mean, standard deviation, skewness and kurtosis of sound speed section

The uncertainties in the ocean physics along one of the PRIMER acoustical path (Fig. 6) are illustrated on Figure 9. An ESSE ensemble of 79 members was used to compute this prior error estimate and the ensemble mean and statistical moments of the deviations from this mean are shown. Of course, the 79 simulations were independent from the physical-acoustical realization that defines the truth. The mean sound-speed section show the shelfbreak front, surface summer thermocline and cold pool (sound channel) on the shelf. The standard deviation is maximum around 35 m depth, in accord with independent data (Glen Gawarkiewicz, personal com.), and has an amplitude of 5m/sec. This depth is where the front surfaces within the middle of the thermocline, near the largest hydrographic gradients and largest internal velocities (shelfbreak front jet). At the front, the skewness is close to 0 and kurtosis close to 3 (relatively Gaussian), except near the surface and bottom boundary layers. Just away from the front, uncertainties are less Gaussian.

Coupled assimilation results for the sound-speed and continuous-wave TL fields are illustrated on Figures 10-11. In this example, the physical data are coarse temperature and salinity measurements sampled in the synthetic ``true'' ocean: 2 CTD profiles are taken over 35 km across the shelfbreak front, along the PRIMER path (Fig. 6). The 224 Hz source is at 300 m depth on that path (bottom left corner). The acoustical data are synthetic towed-receiver TL data, measuring the relative sound intensity received at 224 Hz along that path. The TL observations are made at constant 70 m depth, every 50 m from a range of 150 m to almost the receiver (about 35 km from the source). These are sub-sampled data since the (r, z) acoustic grid resolution is 5 m by 5 m.

The sound-speed (C) residuals before assimilation (prior field residuals), after assimilation of the TL data, after assimilation of both the TL and C data (posterior field residuals), and the error standard deviation estimate for this posterior sound-speed field are on Fig. 10. The true TL, prior TL (i.e. the mean or forecast), TL after assimilation of TL data and TL after assimilation of both TL and C data (posterior TL) are shown in Fig. 11. Even though the sub-sampled data are limited, the posterior C and TL are substantially closer to the true C and TL than the priors. The improvements of both the

TL and sound-speed fields due to the assimilation of the TL data alone, and their subsequent improvements due to the assimilation of the two sound-speed profiles are clearly visible. On Fig. 10, it is interesting to see that the coupled assimilation improves the larger scales of the TL field, the higher loss in the surface thermocline and low loss in the sound channel over the shelf, but also some of the smaller scales (nulls, etc). Similarly, the impact of the sound-speed data (two CTDs) shows the effects of the mainly mesoscale ocean-ocean correlations and multi-scale ocean-acoustic correlations.

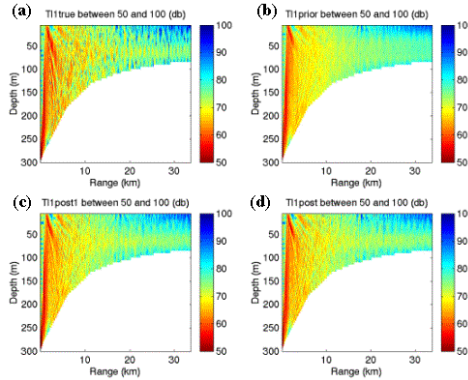

Figure 10. Sound-speed residuals before assimilation, after assimilation of the TL data, after assimilation of both the TL and C data, and error standard deviation estimate for this posterior sound-speed field

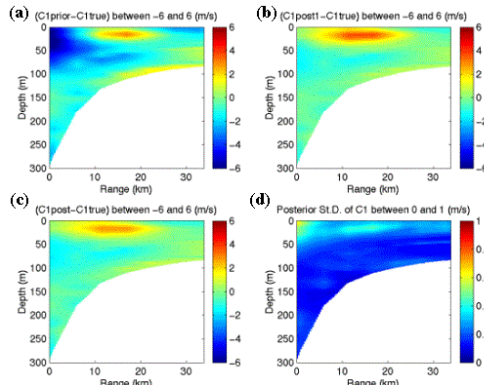

Figure 11. True TL, prior TL, TL after assimilation of TL data and TL after assimilation of both TL and C data

The posterior ESSE ensemble properties (error variance, covariances, etc) importantly estimate the uncertainty reduction as a result of the coupled data assimilation. This is illustrated on Fig.11d. The impact of the 2 CTD profiles (on each side of the positive residuals ``pancake'') is clearly visible. The posterior residuals (Fig. 11c) and posterior error estimates (Fig. 11d) agree on average, but the posterior error estimates are likely too small near the bottom of the summer thermocline (e.g. see residual pancake at about 2.5 db and posterior error at 0.6db). This is likely due to the small ensemble size.

The error covariances utilized in the coupled assimilation are illustrated on Figure 12 within the acoustic vertical section. The ESSE estimate of the covariance/correlation function between TL at a range $r = 3\text{km}$ and depth $z = 30\text{m}$ with the other TL values (top) and with the C field (bottom) are plotted. These fields correspond to a row of the coupled TL-C covariance/correlation matrix. The covariances (Fig 12a) are dimensional; the

correlations are non-dimensional (Fig 12b). Looking at the covariances, for that (r, z) location, a positive change in the TL term at (r, z) is linked to a reduction of the TL term in the acoustic waveguide (cold pool) over the shelf and to a warming (higher sound speed) of the upper thermocline above the shelfbreak front and slight cooling in the bottom boundary layer (e.g. a warming of the slope water and/or steepening of the front). Should a TL measurement be made at this (r, z) location, the coupled ESSE assimilation would influence the TL and C fields over whole section in accordance with these patterns; e.g. increase TL in red regions (more loss), reduce TL in blue regions (less loss). Similar comments can be made for the correlation fields (Fig. 12b). In general, correlation estimates tend to over-estimate the influences at large-scales and covariances are utilized for data assimilation.

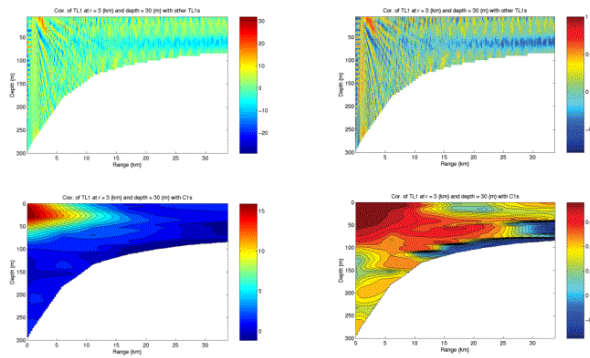

Figure 12. ESSE estimate of the (a) covariance, (b) correlation, function between TL at a range $r = 3\text{km}$ and depth $z = 30\text{m}$ with the other TL values (top) and with the C field (bottom).

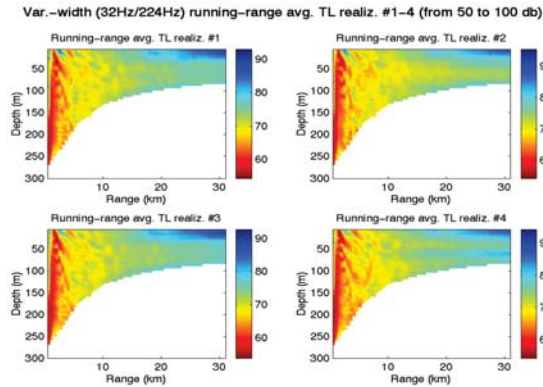

Figure 13. Four realizations of the variable-width running-range average TL field

Broadband TL and impact of DA on the TL term of a passive sonar PPD

To simulate the transfer uncertainties to a broadband sonar system (TL term in a sonar equation), the ensemble of single-frequency (224Hz) TL realizations are processed, using a variable-width running-range average (Figure 13). This is because a variable-width running-range average in space is approximately equivalent to a frequency average around a central frequency as a real sonar does. Four realizations (out of the 79 computed) of the broadband TL estimate are shown on Fig. 13. As expected, the length

scales increase with range. The different realizations (ensemble members) have of course different modal couplings, reflecting the differences in the sound-speed realizations.

To illustrate the impact of the coupled assimilation of physical and acoustical data on the performance of a simulated sonar predictions, the prior and posterior histograms of deviations from the mean broadband TL (i.e., the error PDF estimates) as a function of range and depth are shown on Figure 14. The estimated prior PDFs are found to be depth and range dependent (Fig. 14a). Near the depth (55 m) of the main wave-guide, the predicted error standard deviation is relatively constant with range and relatively large, around 3 to 4 (db). Above (30 m) and below (85 m), standard deviations tend to decrease with range (down to 2 db), leading to a higher PDF peak. After assimilation (Fig. 14b), the uncertainties are reduced to ± 1 db and are more Gaussian at all depths.

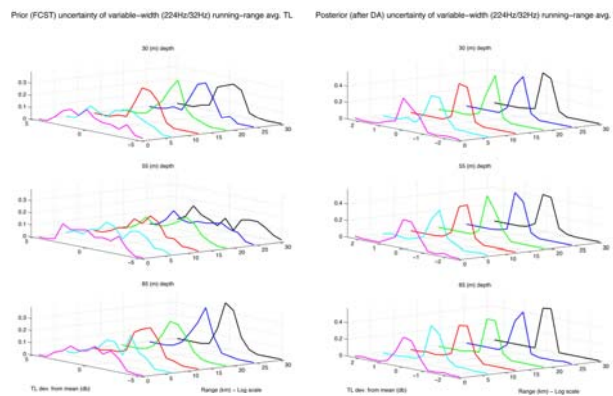

Figure 14. PDF estimates of broadband TL as a function of range and depth, along a PRIMER acoustic path: (a) Prior PDF (predicted by ESSE); (b) Posterior PDF (after ESSE assimilation).

5 Conclusion

Transferring and forecasting uncertainties from the physics, through the acoustics, using ESSE, and processing these dominant error estimates to obtain TL uncertainties for a broadband sonar equation has been demonstrated for an idealized problem using Shelfbreak PRIMER data. ESSE nonlinear coupled assimilation recovered the fine-scale TL structures (10-100m) and the mesoscale ocean physics (10km) from coarse TL data and/or coarse C data. Broadband TL uncertainties were predicted to be range and depth dependent and coupled data assimilation sharpened and homogenized the broadband PDFs.

We are entering a new era of fully interdisciplinary ocean science and ocean acoustics. Ocean prediction systems for science, operations and management are now being utilized. These systems involve interdisciplinary estimation of state variables and error fields via multivariate physical-biological-acoustical data assimilation. This provides novel and challenging opportunities for theoretical and computational acoustics.

6 Acknowledgements

The authors are grateful to Prof. Ching-Sang Chiu (Naval Postgraduate School) for his acoustic propagation contributions to the example. They thank Dr. Phillip Abbot (Oasis, Inc.), Dr. Patrick J. Haley, Jr. and Wayne G. Leslie (Harvard University) for scientific input. We are indebted to Wayne G. Leslie for preparation of the manuscript. This work was supported by the Office of Naval Research under grants N00014-97-1-0239, N00014-02-1-0989 and N00014-00-1-0771.

References

1. Abbot P. and Dyer I., Sonar Performance Predictions Based on Environmental Variability, In "Acoustic Variability, 2002". N.G. Pace and F.B. Jensen (Eds.), SACLANTCEN. Kluwer Academic Press (2002) pp. 611-618.
2. Elisseff P., Schmidt H., and Xu W., Ocean Acoustic Tomography as a Data Assimilation Problem, *IEEE J. Ocean. Engin.* 27 (2002) pp. 275-282.
3. Evangelinos C., Chang R., Lermusiaux P.F.J. and Patrikalakis N., Rapid Real-Time Interdisciplinary Ocean Forecasting using Adaptive Sampling and Adaptive Modeling and Legacy Codes: Component Encapsulation using XML, In "Computational Science - ICCS 2003, International Conference on Computational Science 2003", P.M.A. Slood, D. Abramson, A. Bogdanov, J.J. Dongarra, A. Zomaya, Y. Gorbachev (Eds.). Springer, Lecture Notes in Computer Science, 2660 (2003) pp. 375-384.
4. Fielding S., Crisp N., Allen J.T., Hartman M.C., Rabe B., and Roe H.S.J., Mesoscale subduction at the Almeria-Oran front Part 2: Biophysical interactions, *J. Mar. Sys.* 30 (2001) pp. 287-304.
5. Griffiths G., Fielding S., and Roe H.S.J., Biological-Physical-Acoustical Interactions, In *THE SEA: Biological-Physical Interactions in the Sea, Volume 12* (A.R. Robinson, J.J. McCarthy and B.J. Rothschild, eds.), John Wiley and Sons, NY, (2002) pp. 441-474.
6. Lermusiaux P.F.J., Data assimilation via Error Subspace Statistical Estimation. Part II: Middle Atlantic Bight shelfbreak front simulations and ESSE validation. *Month. Weather Rev.*, **127**(7), (1999) pp. 1408-1432.
7. Lermusiaux P.F.J. and Robinson A.R., Data assimilation via Error Subspace Statistical Estimation. Part I: Theory and schemes. *Month. Weather Rev.*, **127**(7), (1999) pp. 1385-1407.
8. Lermusiaux P.F.J. and Chiu C.-S., Four-dimensional data assimilation for coupled physical-acoustical fields. In "Acoustic Variability, 2002". N.G. Pace and F.B. Jensen (Eds.), SACLANTCEN. Kluwer Academic Press (2002) pp. 417-424.
9. Lermusiaux P.F.J., Chiu C.-S. and Robinson A.R., Modeling Uncertainties in the Prediction of the Acoustic Wavefield in a Shelfbreak Environment. Proceedings of the 5th ICTCA, May 21-25, 2001, in "Theoretical and Computational Acoustics 2001", E.-C. Shang, Q. Li and T.F. Gao (Eds.), World Scientific Publishing Co., (2002) pp. 191-200.
10. Lermusiaux P.F.J., Robinson A.R., Haley P.J. Jr. and Leslie W.G., Advanced Interdisciplinary Data Assimilation: Filtering and Smoothing via Error Subspace Statistical Estimation. Proceedings of Oceans 2002 IEEE/MITS Conference, (2002) pp. 795-802.

11. Lynch J.F., Gawarkiewicz G.G., Chiu C.-S., Pickart R., Miller J.H., Smith K.B., Robinson A., Brink K., Beardsley R., Sperry B. and Potty G., Shelfbreak PRIMER – An integrated acoustic and oceanographic field study in the mid-Atlantic Bight, In *Shallow-Water Acoustics* (R. Zhang and J. Zhou, Editors), China Ocean Press, (1997) pp. 205-212.
12. McCarthy J.J., Robinson, A.R., and Rothschild B.J., Biological-Physical Interactions in the Sea: Emergent Findings and New Directions, In *THE SEA: Biological-Physical Interactions in the Sea*, Volume 12 (A.R. Robinson, J.J. McCarthy and B.J. Rothschild, eds.), John Wiley and Sons, NY, (2002) pp. 1-17.
13. Pinardi N. and Woods J. (Eds.), *Ocean Forecasting: Conceptual Basis and Applications*, Springer Verlag, Berlin, (2002) 472 pp.
14. Robinson A.R., Forecasting and Simulating Coastal Ocean Processes and Variabilities with the Harvard Ocean Prediction System, *Coastal Ocean Prediction* (C.N.K. Mooers, ed.), AGU Coastal and Estuarine Studies Series, American Geophysical Union, (1999) pp. 77-100.
15. Robinson A.R. and Lermusiaux P.F.J., Data assimilation for modeling and predicting coupled physical-biological interactions in the sea, In *THE SEA: Biological-Physical Interactions in the Sea*, Volume 12 (A.R. Robinson, J.J. McCarthy and B.J. Rothschild, eds.), John Wiley and Sons, NY, (2002) pp. 475-536.
16. Robinson A.R., Lermusiaux P.F.J., and Sloan N.Q., Data Assimilation. In *THE SEA: The Global Coastal Ocean*, Volume 10: Processes and Methods (K.H. Brink and A.R. Robinson, eds.), John Wiley and Sons, NY, (1998) pp. 541-594.
17. Robinson A.R., McCarthy J.J., and Rothschild, B.J., Interdisciplinary Ocean Science is Evolving and a System Approach is Essential, *J. Mar. Sys.* **22** (1999) pp. 231-239.
18. Robinson A.R., Abbot P., Lermusiaux P.F.J. and Dillman L., Transfer of uncertainties through physical-acoustical-sonar end-to-end systems: A conceptual basis. *Acoustic Variability 2002*. N.G. Pace and F.B. Jensen (Editors), Saclantcen. Kluwer Academic Press, (2002) pp. 603-610.